

GAMMA instabus

Switching/dimming actuator 2x DALI, Broadcast

RL 526D23

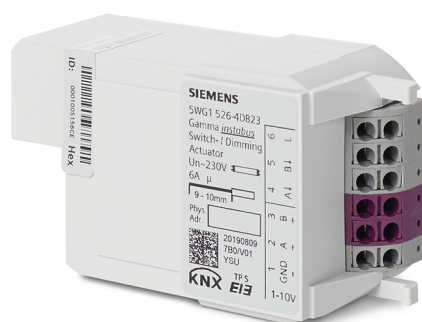

The switching/dimming actuator RL 526D23 is used for switching, dimming and scene control in building automation. Device control is conducted via KNX.

- Control of dimmable electronic control gear (ECG Dynamic) for fluorescent lamps or LED drivers for LEDs via the DC 1 to 10 V control outputs
- Direct switching on and off of the AC 230 V for two lamps (groups of lamps) each with two switching contacts with a capacity of 6 A
- Built-in device for installation in an automation module box AP 118, in a room automation box AP 641 or in a M 590 DIN rail housing, which has to be ordered separately

Functions with configuration with ETS

- Extensive control, override and diagnostic functions for each channel
- Configurable dimming curves and various fade times for optimal dimming
- Control value input for analogous values can be configured as an alternative to the switching input
- Integrated 8-bit scene control and assignment of each output to up to 8 scenes
- Counting of operating hours and switching cycles with threshold monitoring

Characteristics

The switching/dimming actuator RL 526D23 is used for switching, dimming and scene control in building automation. Device control is conducted via KNX.

The switching/dimming actuator is used to switch loads or dim using 1 to 10 V (passive) control outputs. The control voltage of 1 to 10 V is provided via the ECGs or LED drivers.

A load of up to 1380 W can be connected to each switching output of the switching/dimming actuator. ECG or LED drivers can be connected to each control output of the switching/dimming actuator. With a maximum control current of 46 mA, a maximum of 23 ECG or LED drivers with a maximum of 2 mA each can be connected.

The bus connection of the device uses a bus terminal block. The electronics of the device are supplied via the bus voltage (no additional supply voltage required).

The maintenance-free terminals are for connecting solid, fine-stranded and stranded conductors with conductor cross-sections from 0.5 to 2.5 mm² on the load outputs and cross-sections on the control outputs. Stranded and fine-stranded conductors can be plugged into the terminals without ferrules.

Each of the switching/dimming outputs can be assigned different functions depending on the application, i.e. switching/dimming actuator RL 526D23 consists of the device (hardware) and the application program (software).

The switching/dimming actuator RL 526D23 is a built-in device for installation in an automation module box AP 118, in a room automation box AP 641 or in a M 590 DIN rail housing, which has to be ordered separately.

Functions

Building site function

The building site function provided ex-factory enables switching the building site lighting on and off via a sensor and an actuator, even if these devices have not yet been commissioned with the Engineering Tool Software (ETS).

Resetting the device to factory settings

A very long push of the programming button of more than 20 seconds resets the device to its factory settings. This is indicated by a uniform flashing of the programming LED for 8 seconds.

All configuration settings are deleted. The building site function of the delivery state is re-activated.

Behavior on bus voltage failure/recovery

On bus voltage failure, the current switching status and dimming value status for each output are saved permanently so that they can be restored when bus voltage is recovered.

On bus voltage recovery, the configured actions are executed and, if applicable, new status values are reported.

Behavior on unloading the application program

After unloading the application program with the ETS, the unloaded device has no functions. If the programming button is pushed for more than 20 seconds, the device is reset to its factory settings.

Timer functions

When configuring the device with ETS, two different timers and night mode can be programmed. It is possible to set e.g. delayed switching on/off as well as a warning before switching off occurs.

Overrides

Up to seven override function blocks can be activated for the device via the ETS to override the automation functions. For each override function block, one of the following options can be selected:

- Manual override (ON)
- Permanent OFF
- Lock
- Central override
- User-defined override function

- Forced control

Switching cycles and operating hours count

To monitor use, the right configuration makes it possible to count and display the switching cycles and operating hours of the device.

8-bit scene control

Using 8-bit scene control, current brightness values or switching states can be assigned to a scene and activated again later through the scene.

Schematic design of a dimming channel

The following schema illustrates the listed functions in a logical overview.

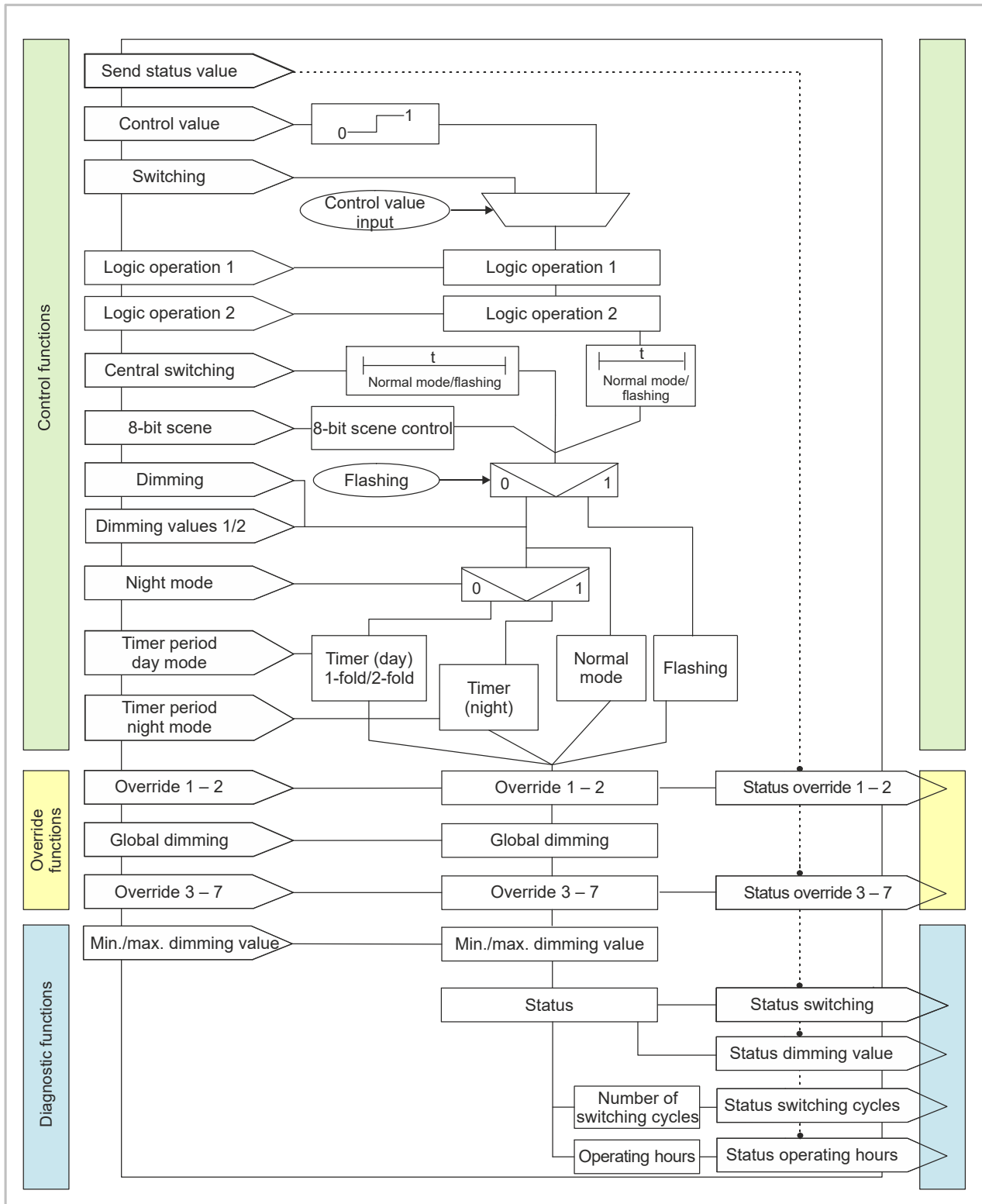

Fig. 1: Schematic design of a dimming channel

Position and function of the connections, operating and display elements

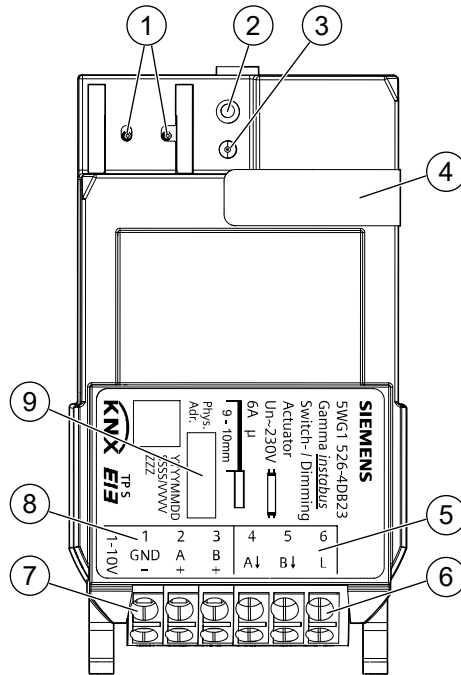



Fig. 2: Connections, operating and display elements

Pos.	Connection, operating or display element	Function
1	Connection pins for KNX bus terminal block	Connect KNX bus
2	Button: Programming mode	Short push of button (< 2 s): <ul style="list-style-type: none"> Activate programming mode, display status (programming LED on = active)
3	Programming LED (red)	Very long push of button (> 20 s): <ul style="list-style-type: none"> Reset to factory settings (programming LED starts flashing after 20 s)
4	Label with barcode of the device	Two copies of the barcode are printed on it. The second barcode can be separated to facilitate commissioning and, for example, be kept with the documents for the project.
5	Labeling of switching contacts for the channels	
6	Connection terminals of the switching contacts	Connect input and loads
7	Connection terminals of the control outputs	Connect electronic control gear (ECG)
8	Labeling of the control outputs	
9	Label field	Enter physical address

Type overview

Type	Description	Article number	KNX PL-Link
	Switching/dimming actuator RL 526D23 2 x AC 230 V, 1...10 V	5WG1526-4DB23	yes



Scope of delivery

Module for installation in AP 118 automation module box, in AP 641 room automation box or in M 590 DIN rail housing.

Version of the Engineering Tool Software

Application	Version
Engineering Tool Software (ETS)	ETS 4.2 or above

Accessories

Type	Order number	Description
	5WG1118-4AB01	Automation module box AP 118
	5WG1641-3AB01	Room automation box AP 641
	5WG1590-8AB01	M 590 DIN rail housing

Product documentation

Documents related the product, such as operating and installation instructions, application program description, product database, additional software and CE declarations can be downloaded from the following website:

<http://www.siemens.com/gamma-td>



Frequently asked questions

For frequently asked questions about the product and their solutions, see:

<https://support.industry.siemens.com/cs/products?dtp=FAQ&mf=ps&lc=en-WW>



Support

Contact details for additional questions relating to the product:

Tel.: +49 89 9221-8000

<http://www.siemens.com/supportrequest>



Security

The device is designed to be installed in an AP 118 automation module box, in an AP 641 room automation box or in a M 590 DIN rail housing.

 **CAUTION**
**National safety regulations**

Failure to comply with national safety regulations may result in personal injury and property damage.

- Observe national provisions and comply with the appropriate safety regulations.

 **WARNING**

- The device should only be installed and put into operation by a certified electrician.
- When connecting the device, ensure that the device can be enabled.
- Do not open the casing of the device.
- Secure the phases with a B16 line protection switch.
- Only use loads that are approved for dimming operation.
- For planning and construction of electric installations, the relevant guidelines, regulations and standards of the respective country are to be considered.



If you pass on the device, ensure you also pass on the documentation for the device, such as, the operating instructions.

Commissioning

**Areas of use**

The device is installed in an automation module box AP 118, in a room automation box AP 641 in dry interior spaces or in a M 590 DIN rail housing.



- Electrical expertise is required for the installation.
- The installation must be performed by a specialist.
- Do not open the casing of the device.

Incorrect installation can deactivate electrical safety features without this being apparent to a lay person.

Connecting loads to the switching contacts and control outputs

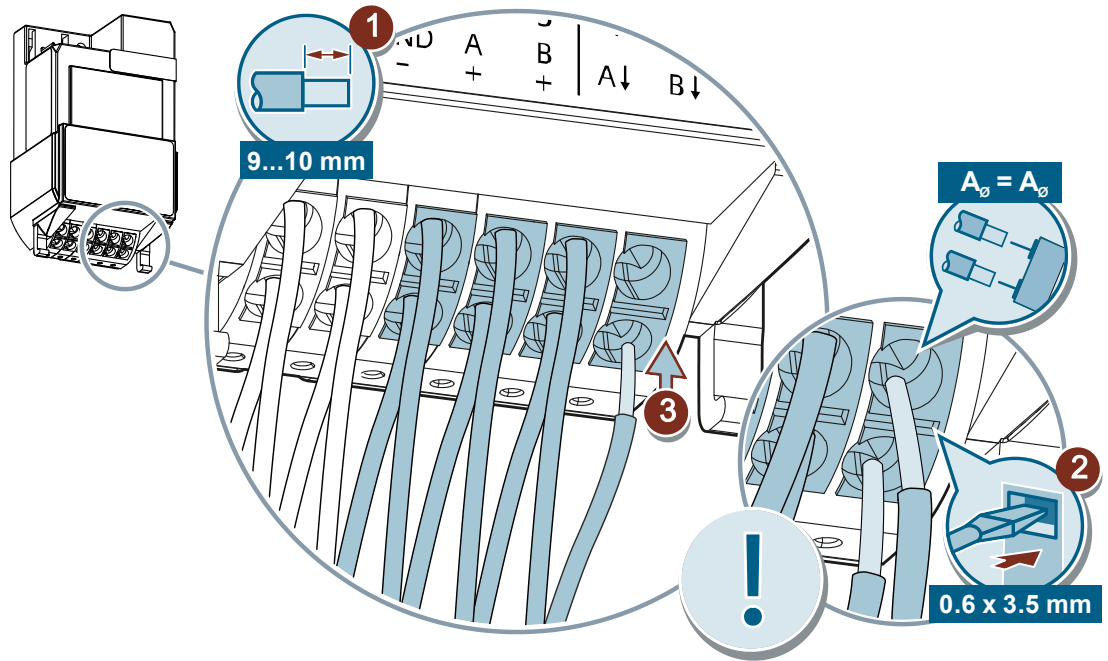
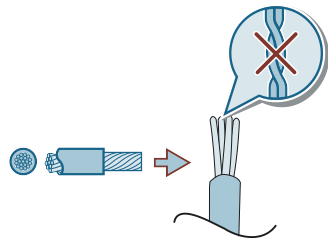

Fig. 3: Connecting loads to the switching contacts and control outputs

Cu	
	0.5... 2.5 mm ²
	2.5 mm ²



Connecting KNX

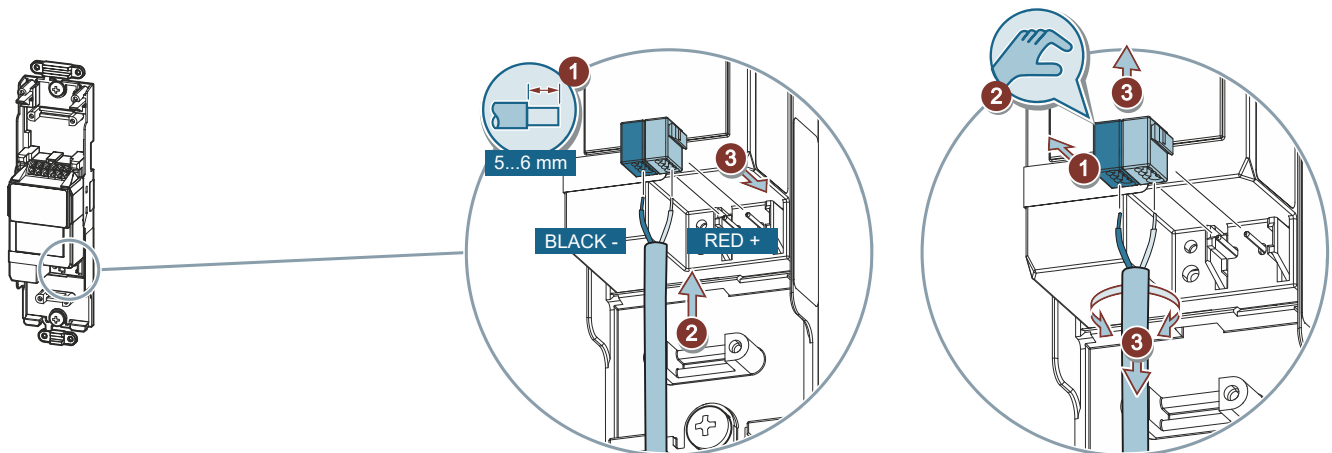



Fig. 4: Connecting KNX

Cu	
	0.6...0.8 mm

Test

Test of KNX 24 V DC type SELV

This test can be used to check whether the bus connection cable is connected with the correct polarity and whether device is supplied with bus voltage.

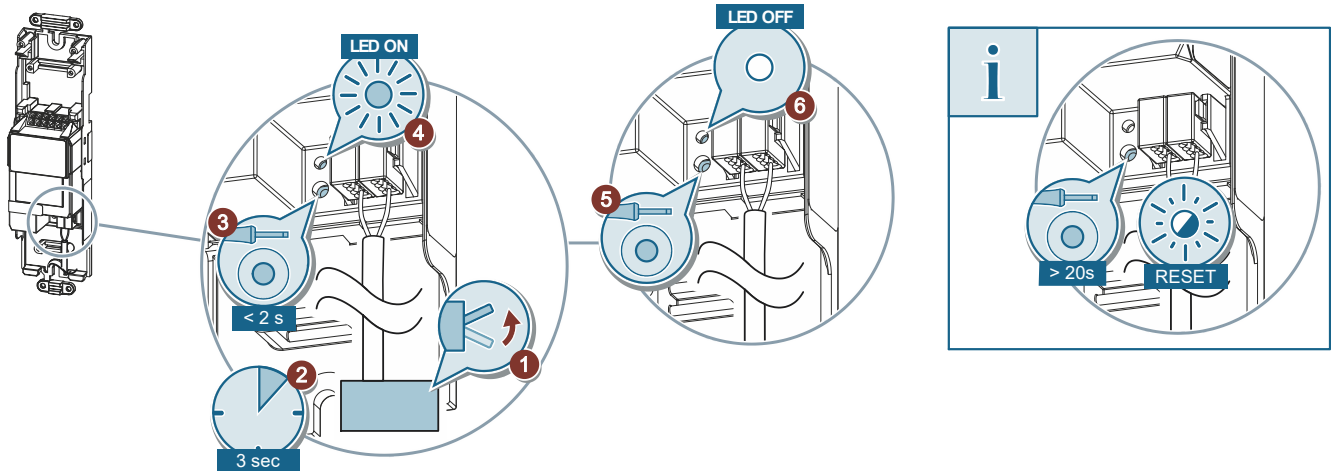

Fig. 5: KNX test

If the programming button is pushed for more than 20 seconds, the device is reset to its factory settings.

Disposal



Defective devices can be returned to the appropriate sales office with a return delivery note. To do this, contact support: Product documentation and support [▶ 7]



The device is considered an electronic device for disposal in accordance with European Directive and may not be disposed of as domestic waste.

- Use only designated channels for disposing the devices.
- Comply with all local and currently applicable laws and regulations.

Power supply	
KNX bus voltage	DC 24 V (DC 21...30 V)
KNX power consumption via bus	15 mA
KNX power consumption (internal consumption)	0.26 W

Drive channels	
Number of load relays (bi-stable relays, potential-free)	2
Contact voltage	
Rated voltage*	230 V
Contact current	
Rated current per channel	6 A
Rated current AC1 operation (cosφ = 0.8)	6 A

* The mains supply line to the device must be protected by a circuit breaker of characteristic B for a max. rated current of 16 A.

Service life	
Mechanical lifespan	10,000,000 switching cycles
Electrical lifespan	100,000 switching cycles
Power loss**	
Maximum power loss per device at rated output	2.4 W
Maximum power loss per output at rated output and maximum resistive load	1.1 W
Switching capacities/load types, loads	
Resistive load	1380 W
Minimum switching capacity	5 V 100 mA
Maximum DC1 breaking capacity	30 V 6 A

**** Power loss for installation in room automation box AP 641**

When using RS or RL modules in a room automation box AP 641, take their power loss into account.

The power loss generated by an RS or RL module depends on the loads that are connected to the channels of the respective module, and consists of the power loss of the device and the power loss of the individual channels.

0.36 W + power loss channel A + power loss channel B

Power loss of device "RL 526D23"	0.36 W
Formula for calculation the power loss per channel: $0.0153 * (\text{load check individual channel [A]})^2 + 10.1 * \text{ECG current channel [A]}$	
Number of channels	2 (A and B)

Room automation box AP 641 diverts the power loss of the installed modules to the environment. The entire dissipative power loss P_v depends on the ambient temperature of the room automation box.

For more information and an example of the calculation for determining the overall power loss of all RS or RL modules in a room automation box AP 641, refer to the TPI for room automation box AP 641 (5WG1641-3AB01).

Incandescent lamps	
Rated output for incandescent lamp	1380 W
Rated output for HV halogen lamp	1380 W

Outputs (control outputs, 1...10 V)	
Number of control voltage outputs DC 1 to 10 V (passive)	2
Control voltage on control output on bus voltage failure 1 to 10 V (passive)	10 V (maximum brightness)
Maximum permissible control current	46 mA
Max. number of ECG or LED drivers (2 mA per ECG) with maximum control current	23
Maximum line length with maximum permissible power and control voltage on control output 1 to 10 V (passive)	70 m

Physical specifications	
Housing material	Plastic
Dimensions	Dimensions [▶ 13]
Weight (device), approx.	66 g
Fire load	2 MJ

Environmental conditions	
Ambient temperature in operation	-5...+45 °C
Storage temperature	-20...+70 °C
Transport temperature	-25...+70 °C
Relative humidity (non-condensing)	5...95 %
Environmental category (as per EN 60721-3-3)	EN 50428

Protection settings	
Degree of pollution (as per IEC 60664-1)	2
Overvoltage category (as per IEC 60664-1)	III
Device protection class (as per EN 60529)	IP20
Electrical safety, bus	Safety extra low voltage SELV DC 24 V
Electrical safety, device complies with	EN 50428
EMC requirements, device complies with	EN 50428

Reliability	
Failure rate (at 40°C)	405 fit

Connection example

The following example shows the connection of 2 dimmable electronic control gear units (ECG Dynamic) for fluorescent lamps on the DC 1 to 10 V control outputs of channels A and B. In addition to that, the lamps are connected to the switching contacts of channels A and B for direct switching on and off.

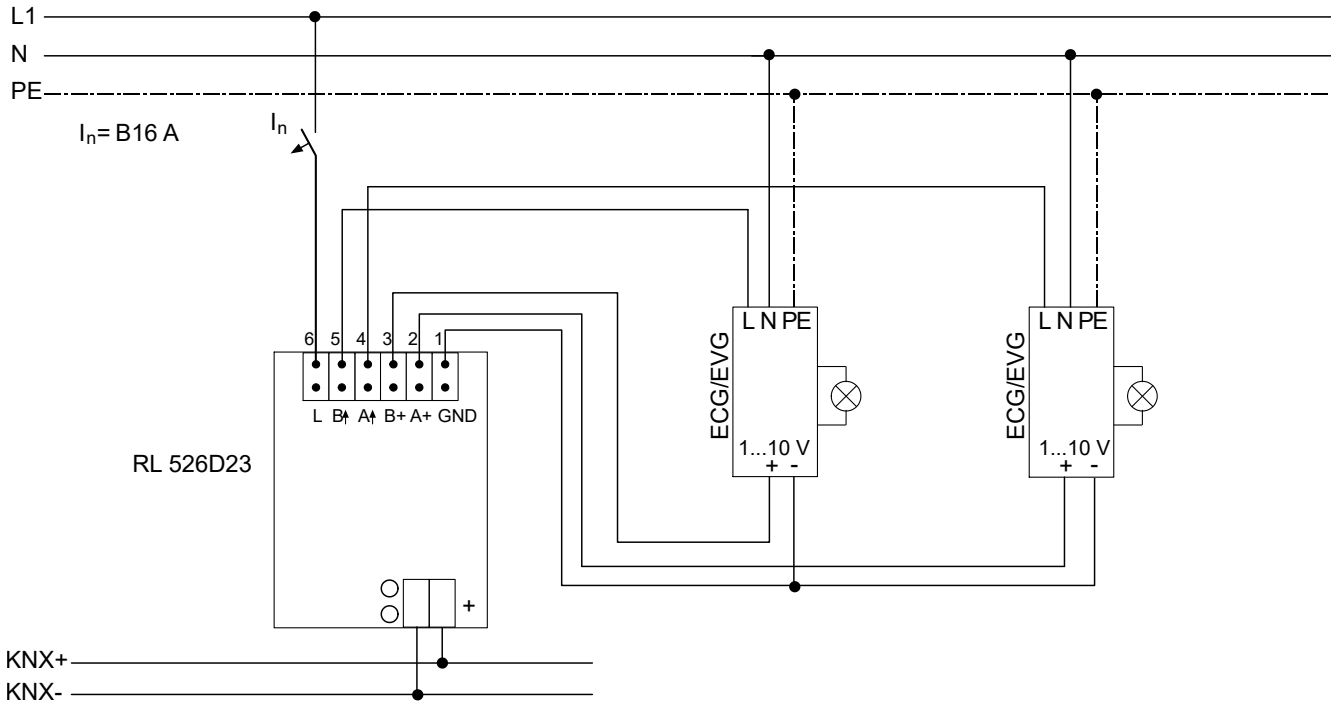
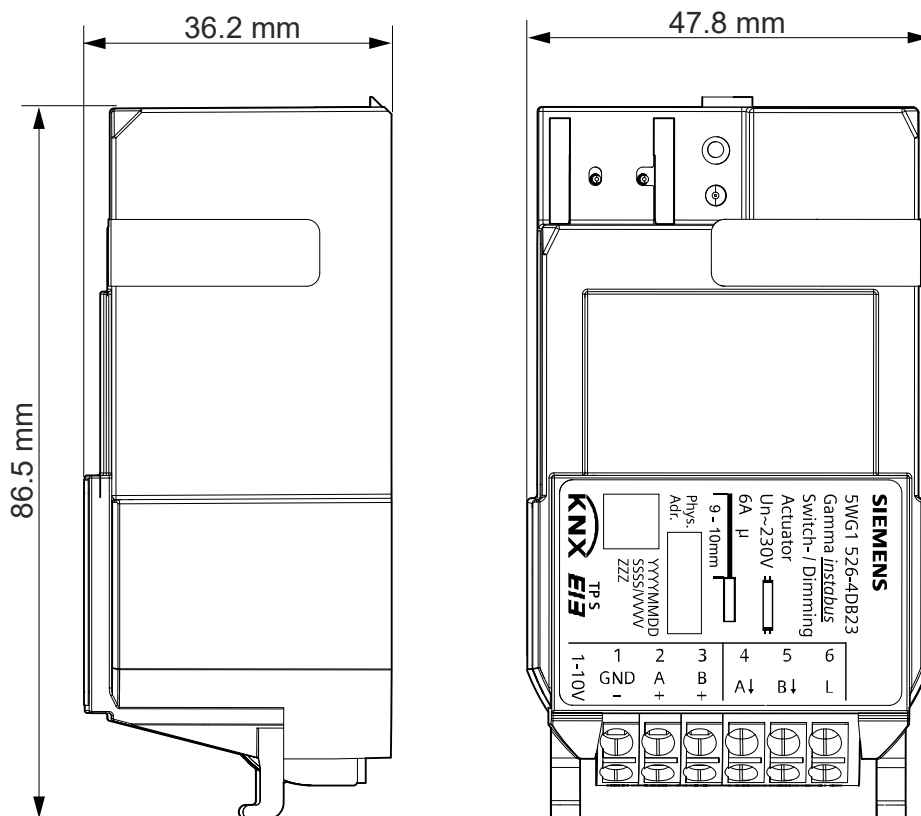

Fig. 6: Connection example

Dimensions



Issued by
Siemens Switzerland Ltd
Smart Infrastructure
Global Headquarters
Theilerstrasse 1a
CH-6300 Zug
+41 58 724 2424
www.siemens.com/buildingtechnologies

© Siemens 2023
Technical specifications and availability subject to change without notice.